

ASSEMBLY MANUAL FOR THE WA3TFS 20 WATT LINEAR QRP AMPLIFIER

updated 04/13/2025

Thank you for the purchase of the amplifier. Sometimes you just need a little more power than the traditional 5 watts for QRP operation on the HF bands.

DESIGN DETAILS

This amplifier has been designed for the 40 meter amateur band but may be constructed for 160, 80, or 20 meters and above as well. Power output may drop on the 10 meter band. For other bands than 40 meters, the values of some components will need modification, but the layout remains the same. The part values that may need to change include U\$2, U\$5, U\$6, C9, C12, C13, C14.

The amplifier is RF actuated so when RF is applied to the input, the amplifier is switched from throughput to active and power is applied to the amplifier components by Q3. Provisions are made to drive LEDs indicating power on, and transmitting. The time that the amplifier is held in the active situation is adjusted by the value of C16. Typically this value is 2 to 4.7 uF for slower speed CW and C16 not mounted for zero value for SSB or high speed CW transmission. The bias voltage applied to the final FETs is adjustable and can be adjusted for lower output if desired. Details are in the "ADJUSTMENT PROCEDURE" section of this manual.

The circuit board measures 2.75" x 3.25" and is configured to use the aluminum enclosure as a heat sink for the finals. You can instead, use an actual heatsink. The circuit board is high quality F4 fiberglass material with plated through holes, solder mask on both sides and a silkscreen image to indicate placement of all components. The amplifier is designed to be powered by up to 13.7 volts DC and driven with up to 5 watts input that will output at least 20 watts RF on the 40 meter band. Four mounting holes are provided for #4 screws. The board must be elevated above the mounting surface to clear the final transistors so use spacers when mounting to enclosure.

Before doing any assembly, use the bare circuit board as a drill template to indicate where the mounting holes are located on your enclosure. Be sure to also mark the location for the final FETs mounting.

ASSEMBLY PROCEDURE

The recommended assembly procedure is designed to aid ease of assembly. Just follow the order shown and the assembly will go smoothly. Shown here In FIGURE 1 is the un-assembled circuit board. Use this un-assembled board to mark the locations of the four mounting holes and the two locations for the final FETs mounting.

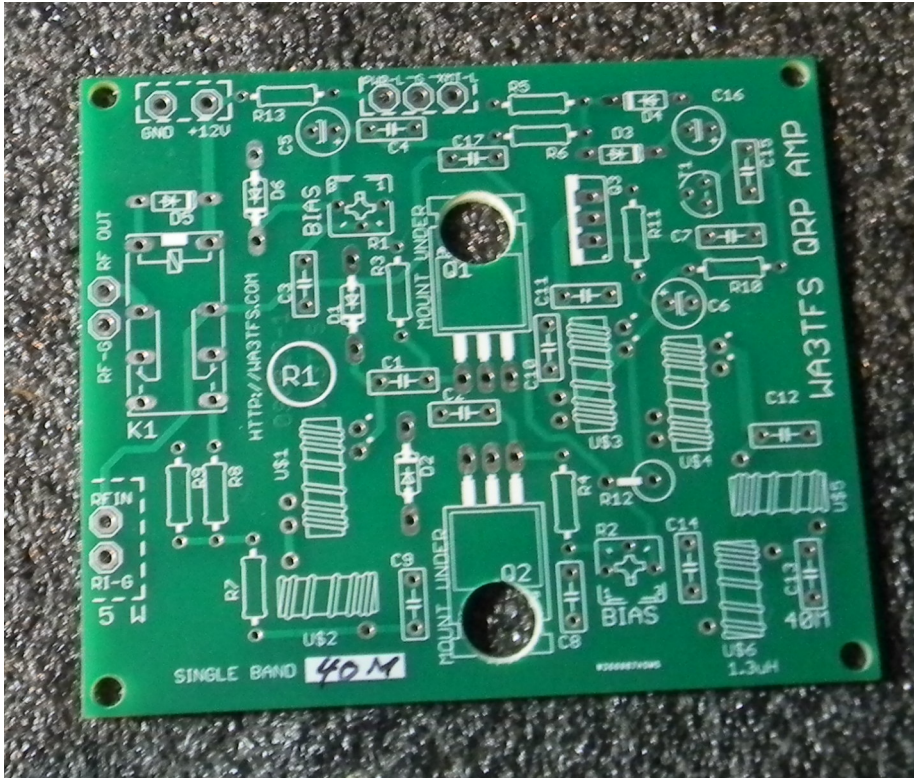

FIGURE 2 shows the installation of the three 1N4148 switching diodes, the two protective zener diodes D1 and D2 are not to be installed, just leave open, and mount the bias Regulator diode D6. Also installed at this time is the 2N3904 transistor that switches the relay when RF is detected on the RF input jack.. Be sure to follow the polarity indicated on the silkscreen.

NOTE:

DO NOT INSTALL DIODES D1 AND D2. They are for test purpose only.

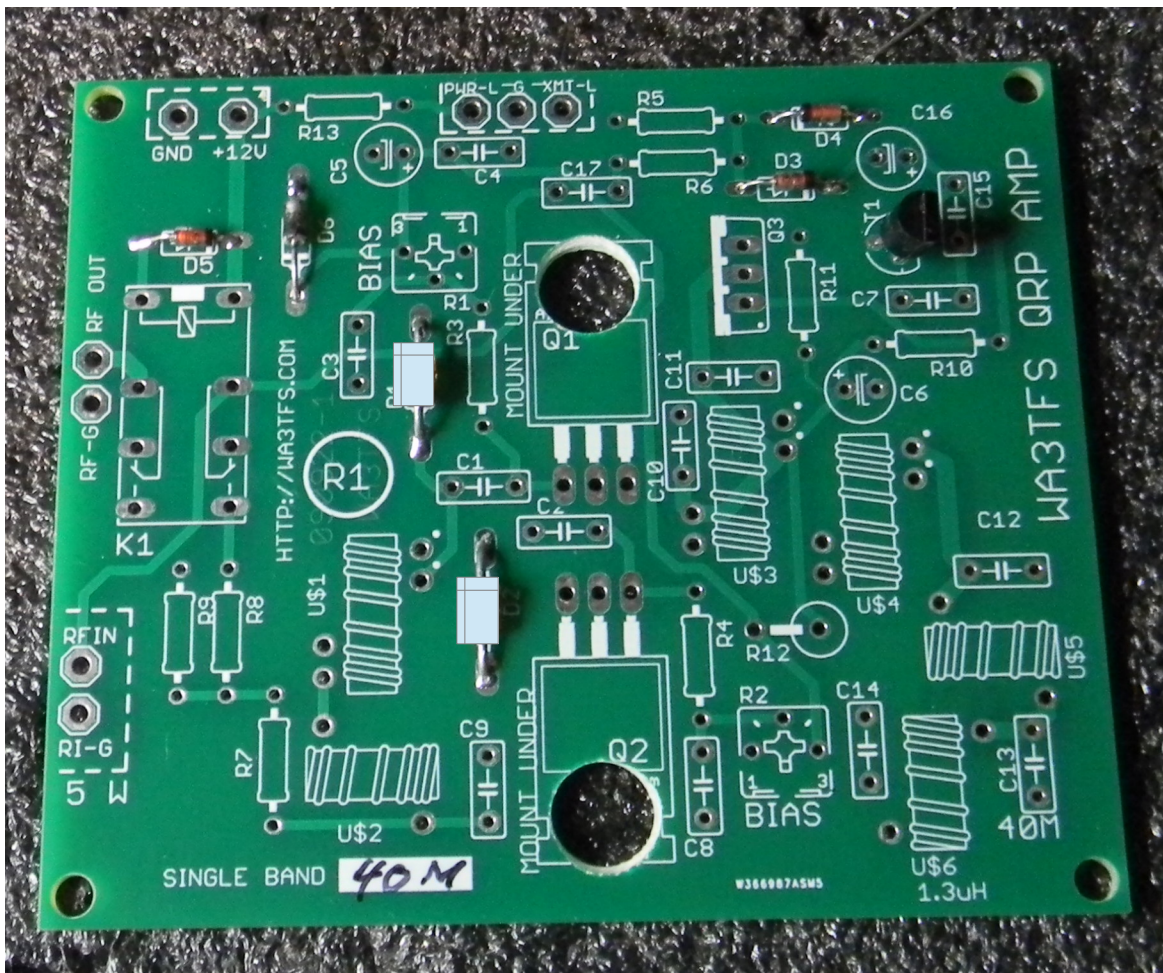

FIGURE 3 now shows the installation of the ceramic capacitors, C1, C2, C3, C4, C7, C8, C10,C11, C15, and C17. Insert the capacitors, solder, and trim the protruding leads.

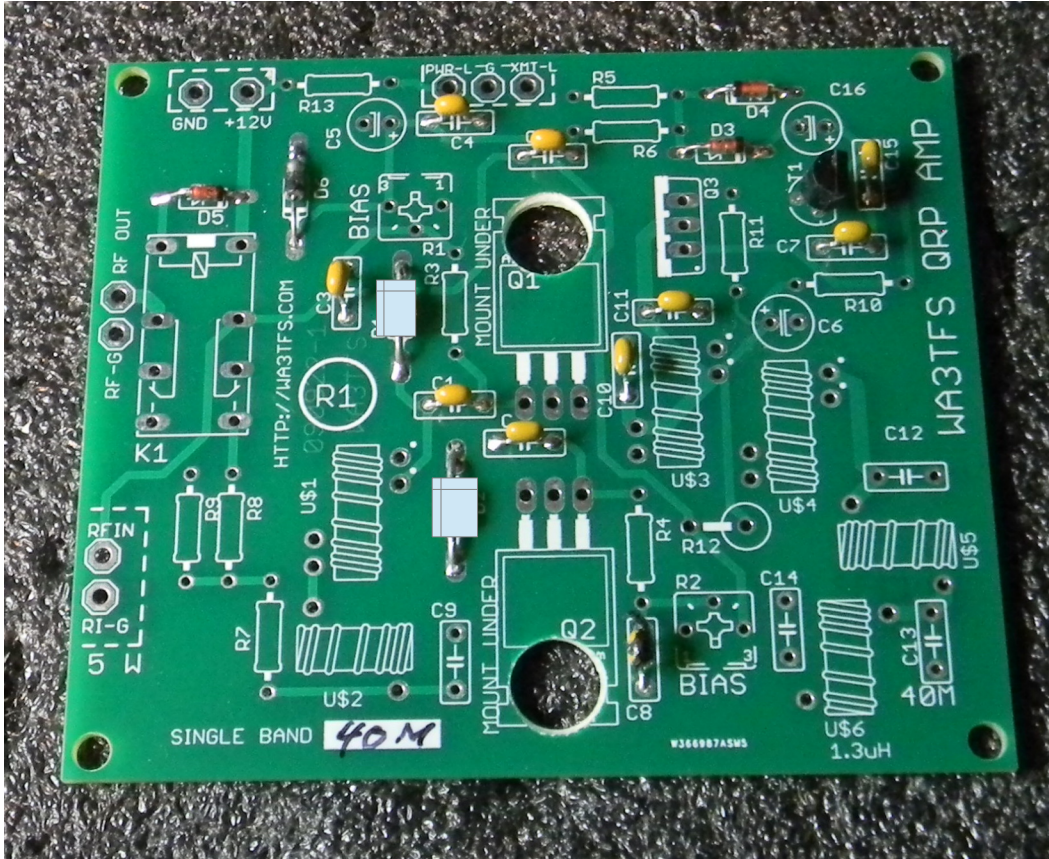
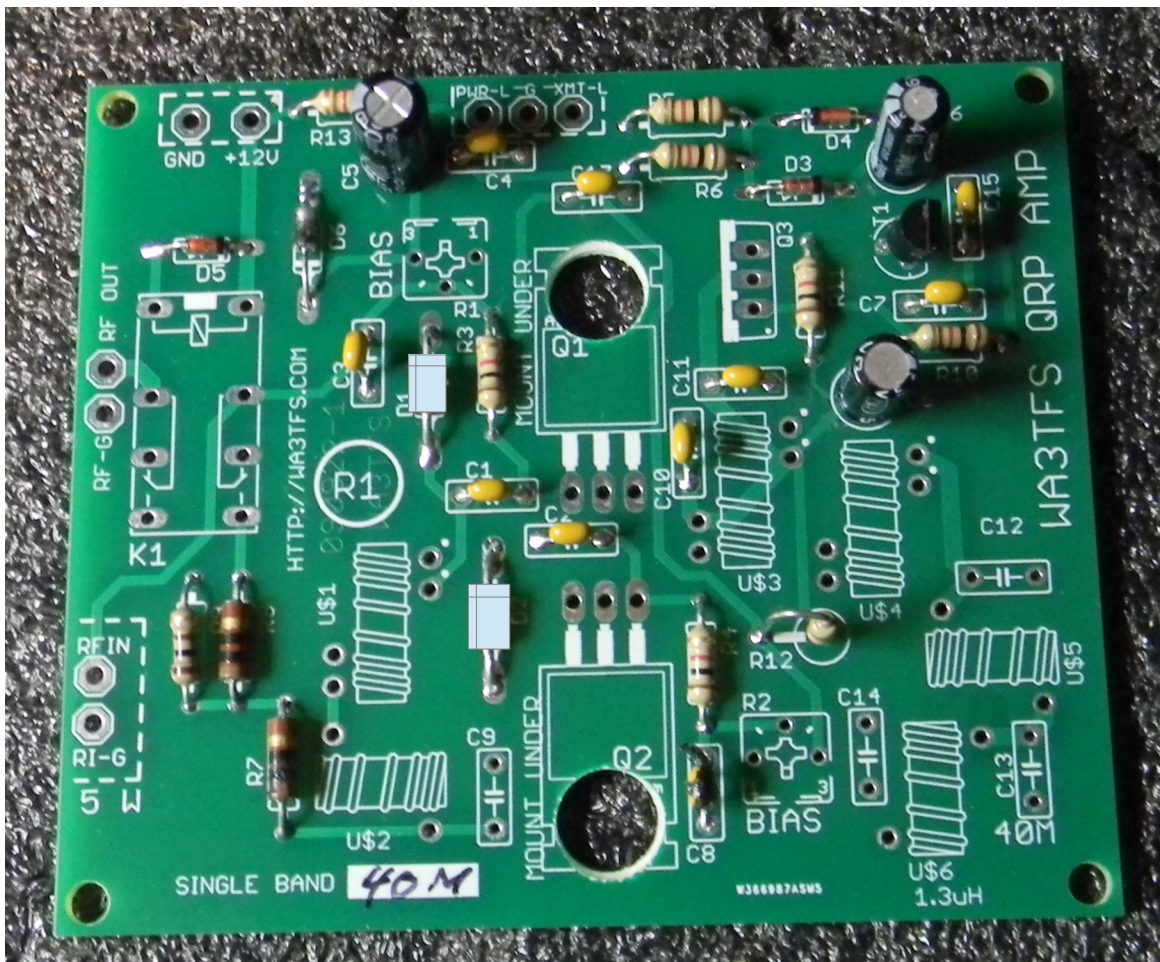

FIGURE 4 shows the installation of all resistors. Each value is detailed on the parts listing. Each are quarter watt resistors and should be mounted flush with the board, except for R12 that is mounted upright as shown. R7, R8, and R9 are used to provide a better match on the input to the amplifier for the driving transmitter. Also shown is the electrolytic capacitors mounted. Note that C16 may or may not be used as it controls the time the amplifier stays active once triggered. Read the note on the schematic to determine if you wish to use this capacitor. You could also add a switch to add the capacitor or none if desired. Note: Resistors 7, 8, 9 are 3 watt and mounted upright if the amplifier is to be used for other than ssb transmission. The $\frac{1}{4}$ watt resistors shown may overheat on FT8 or CW. The 3 watt resistors are specified in the parts listing.



Note: R7, R8 and R9 are higher power resistors from those shown here. Refer to parts list for details.

FIGURE 5 details the installation of the relay. (It fits only in one orientation). Also the P channel Mosfet Q3 is mounted. It should be installed in the board as shown, soldered and excess leads removed under the board. Be sure to orient the tab in the direction shown here. No heatsink is used on this device. It switches power to the amplifier components when RF is detected on the input to the amplifier.

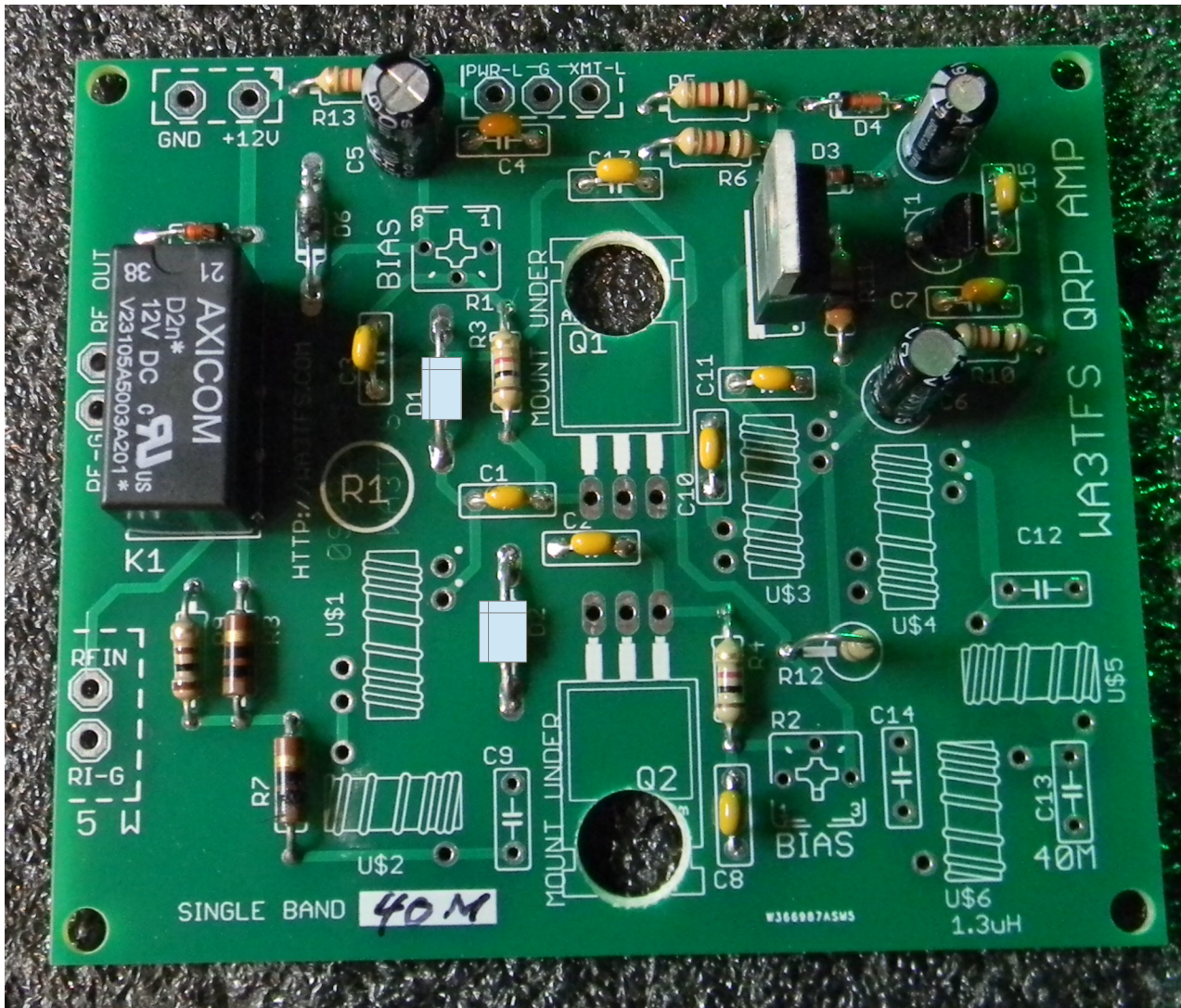

FIGURE 6 Install the two BIAS adjust potentiometers, solder them and then adjust both fully counter-clockwise. Use a small heatsink on Q3 at final assembly.

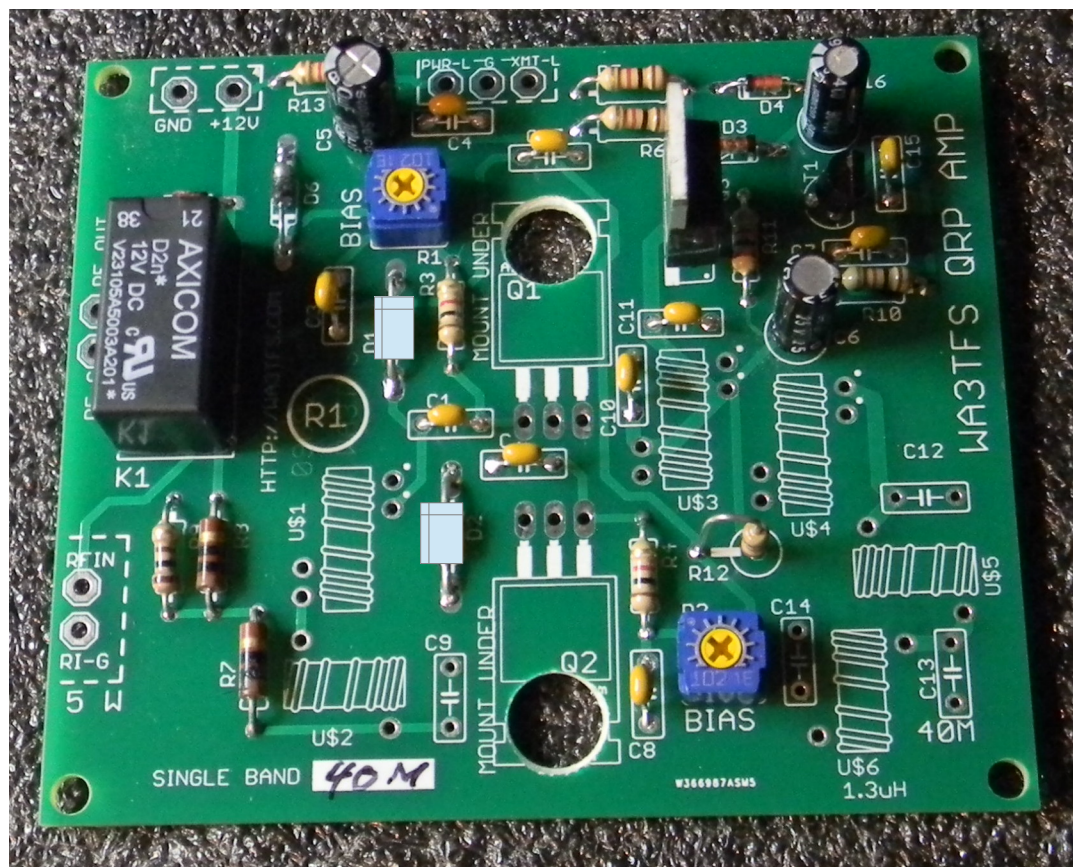
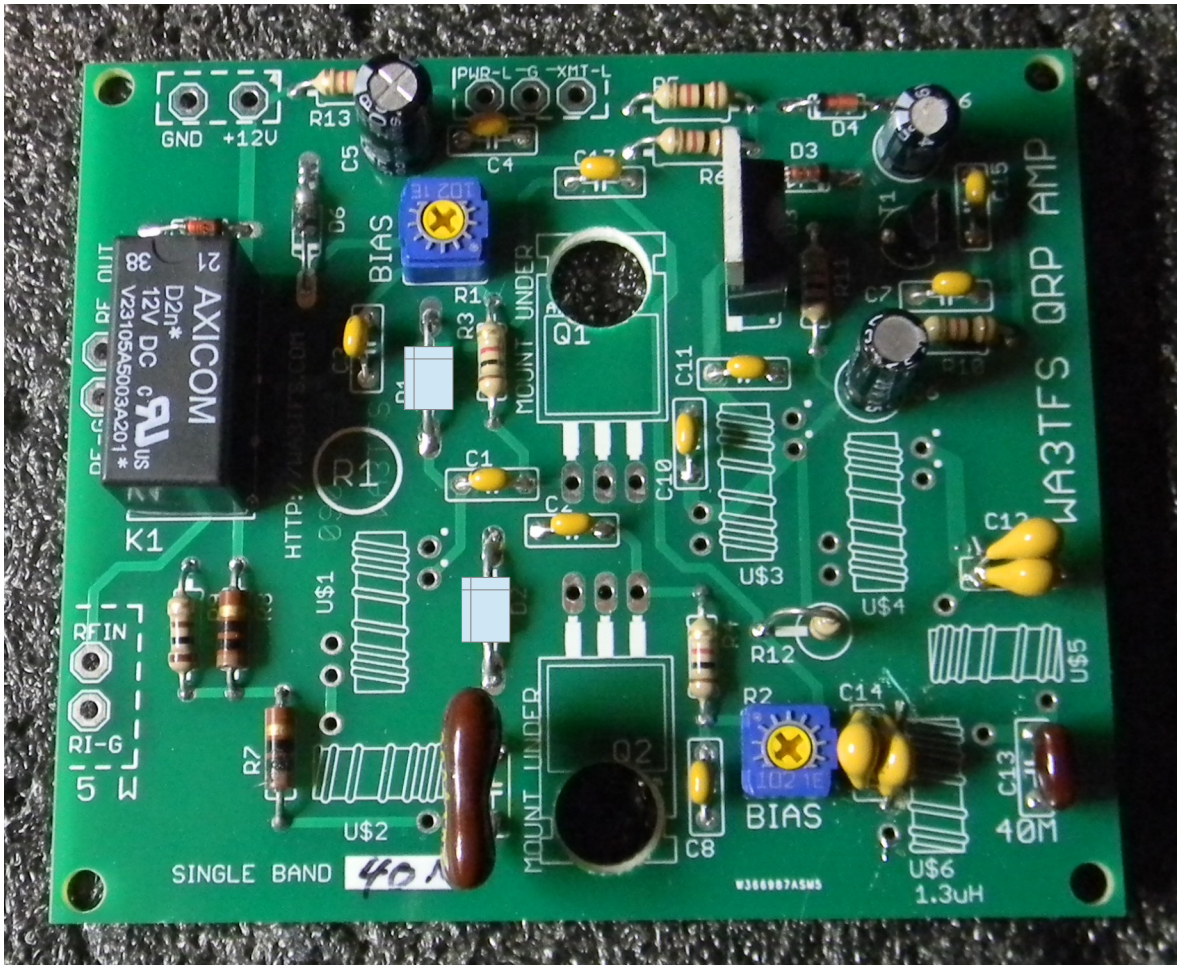
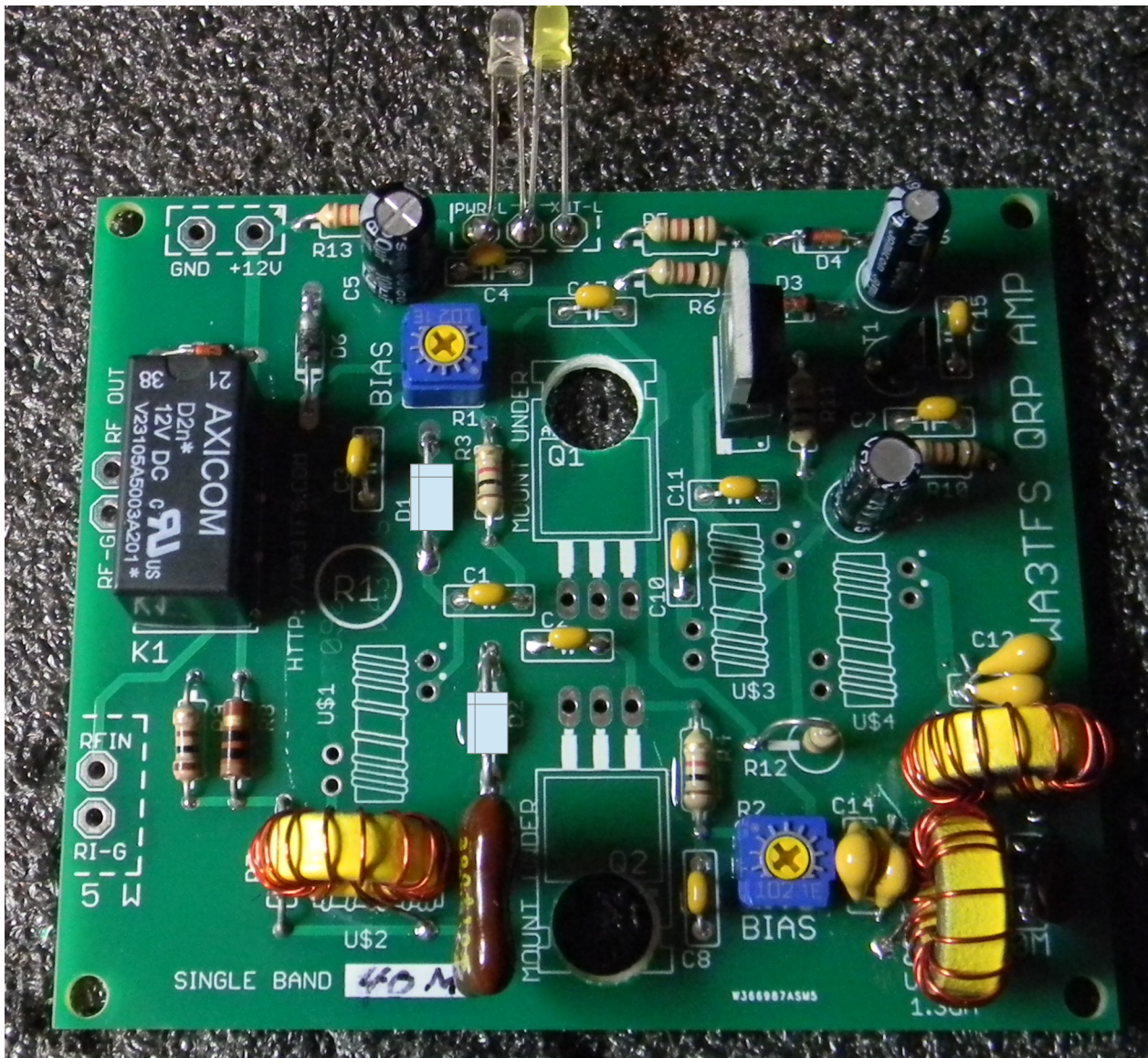

FIGURE 7 Install the capacitors in the tuned sections of the circuit. In the photo, I have combined some capacitors to match the required values at C12 and C14, but just install the components detailed on the parts list. Capacitors installed at this stage are C9, C12, C13, and C14.



-

FIGURE 8 It is now time to wind some inductors. Three inductors are identical. Each have 18 turns of number 24 enamel wire wound on a T50-6 powdered iron toroid core. Each time the wire passes through the center hole is considered one turn. Pull the wire tight at each winding. These three inductors are designed to be 1.3 uH. The inductor at U\$2 along with C(form a low pass filter with roll off beginning around 11 MHz. Remove the enamel coating on the ends of the wires, insert into the circuit board and solder. You may wish to put a drop of super glue under each inductor to hold them in position as that will relieve stress on the wires especially if the amplifier is to be moved around. Install these inductors at U\$2, U\$5 and U\$6 positions. LEDs have also been installed temporarily for testing.



For 80 meters, U\$5 and U\$6 are 21 turns, #24 wire in T50-6 cores (2.4uH) C12, C14= 820pF, C13=1500 pF. All other components are the same as on the parts list.

FIGURE 9 Three more inductors are installed at this stage. Two of them are identical. U\$1 and U\$3 are bifilar wound on a FT50-43 ferrite toroid core. Bifilar just means that two wires are wound at the same time on the core. You can twist them together (about 2 turns per inch) but that is not necessary. It is easier to identify each winding if you use two different colors of wire. Make 10 turns of two wires on the core, strip the enamel coating, and install on the board. For instance, if you use red and green wires, red is the top wire on each side of the core. Take care to orient this inductor properly. Next, another inductor must be assembled. This inductor U\$4 matches the final amplifier FETs to the tuned 50 ohm low pass filter. Take another FT50-43 ferrite core, and wind 14 turns of number 24 wire tightly on the core. Then, wind 5 turns of number 24 wire over the first winding. Space the turns out on the core. Clean the enamel coating off the wires and install on the boards. Be sure the 14 turn winding is installed as the secondary (to the low pass filter) and the 5 turn winding toward the FETs.

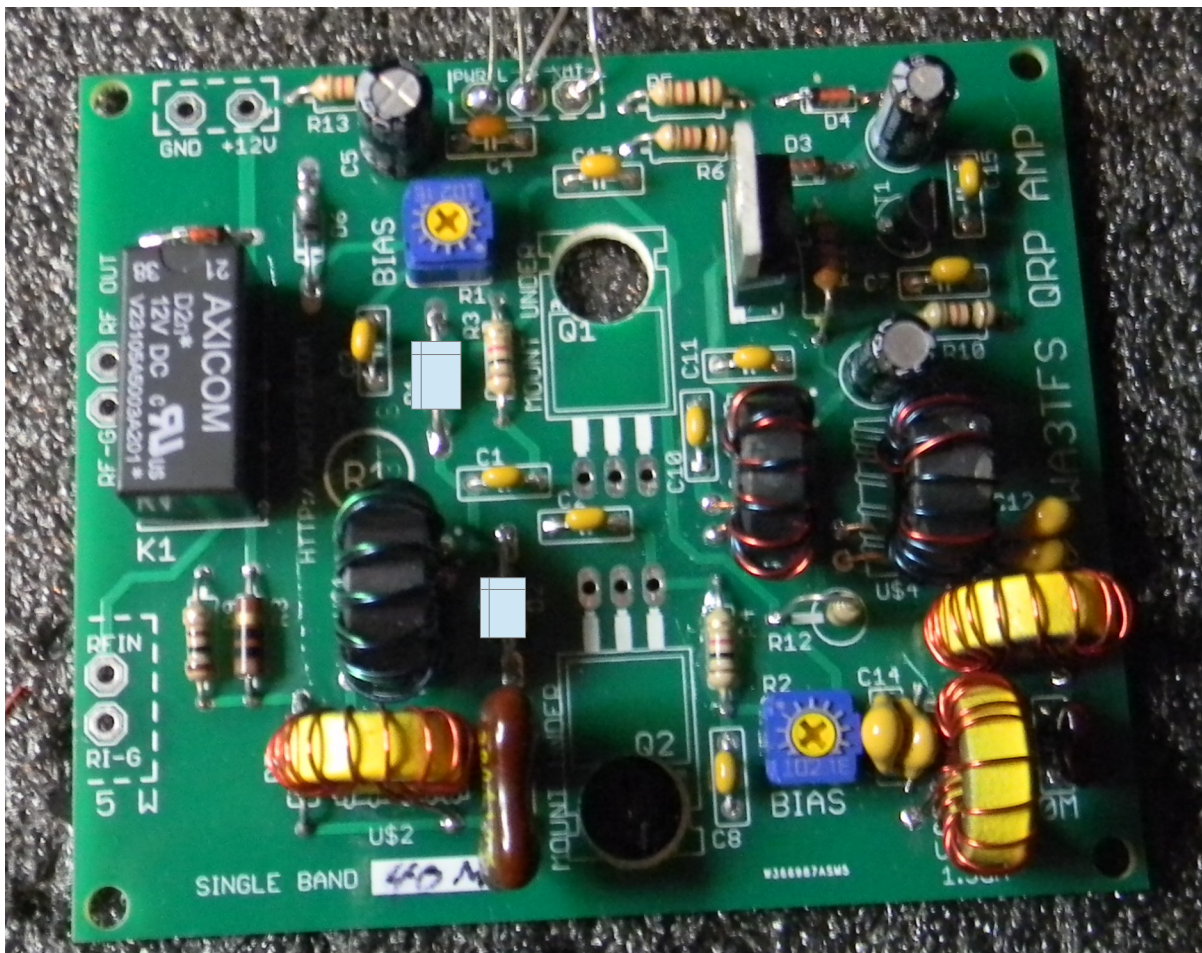

FIGURE 10 You have now completed the wiring of the amplifier circuit board. Inspect all solder connections and make sure all inductors are installed properly. Refer to the schematic if you have any questions. Select the two final FETs (Q1 and Q2) and bend the leads as shown. These can now be mounted to the enclosure or heatsink using insulating pads so as not to short the tab to the heatsink or enclosure. Mount them loosely at this point. The leads will install from beneath the board and be soldered to the board on top in the next step.

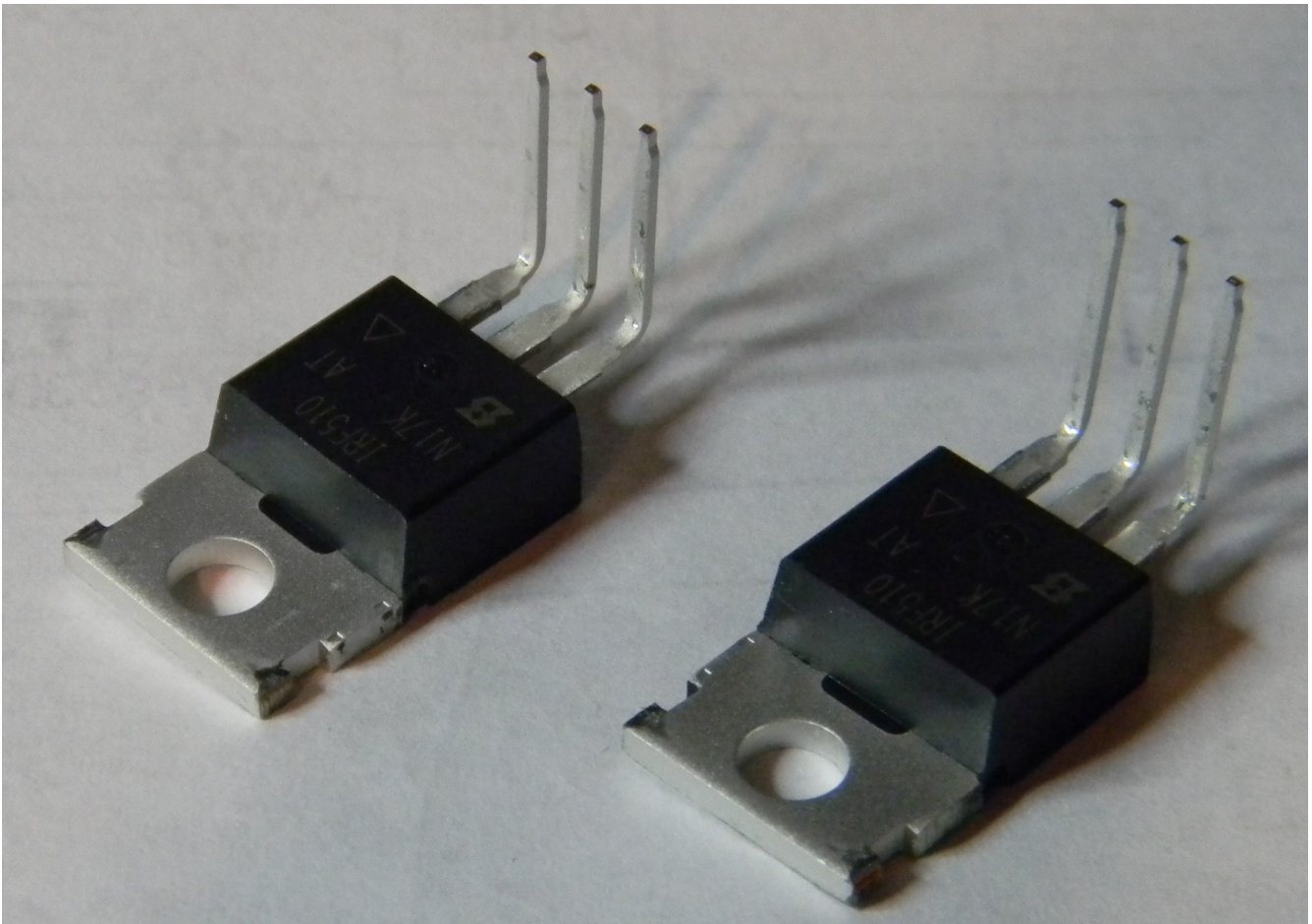
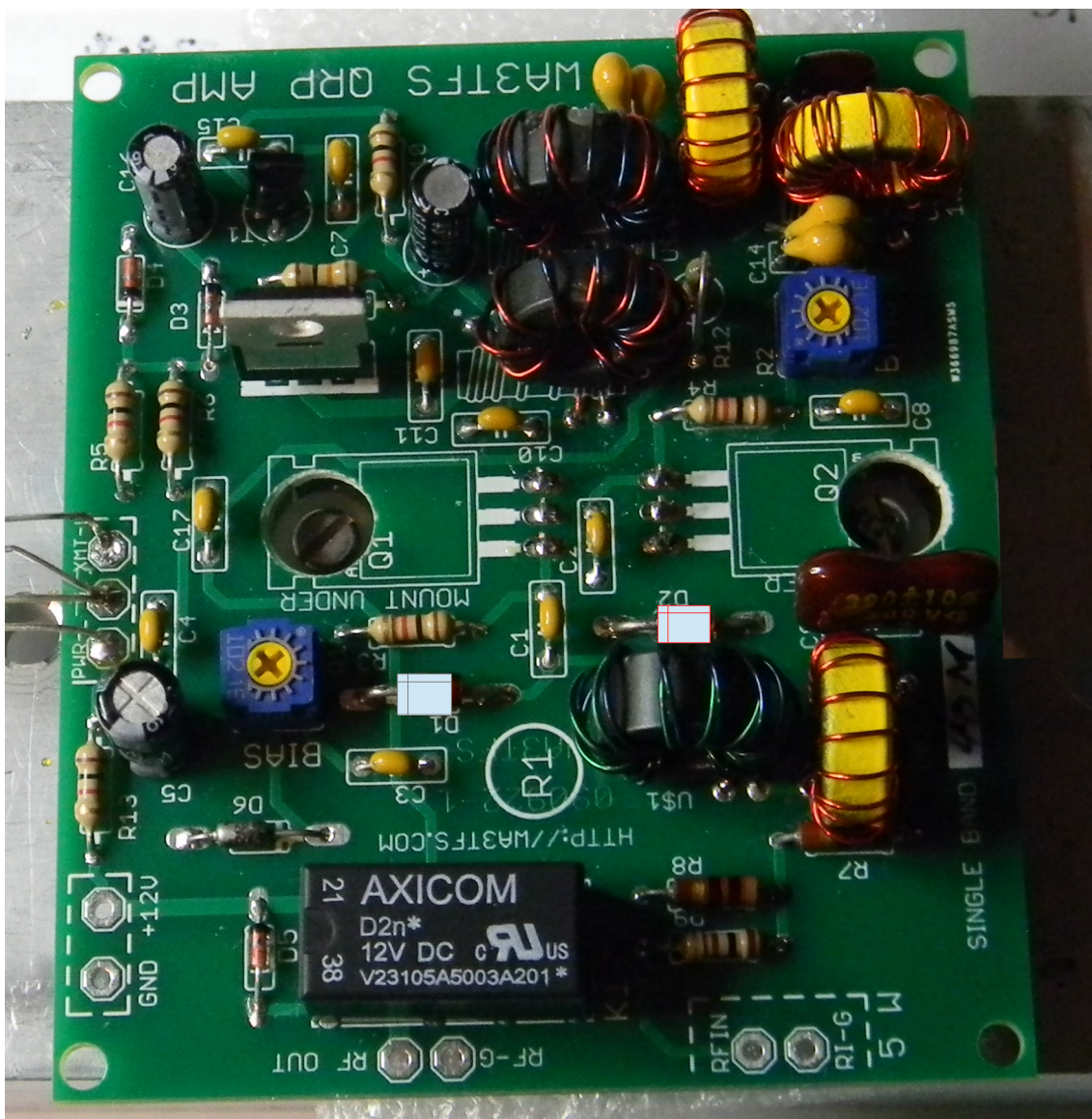
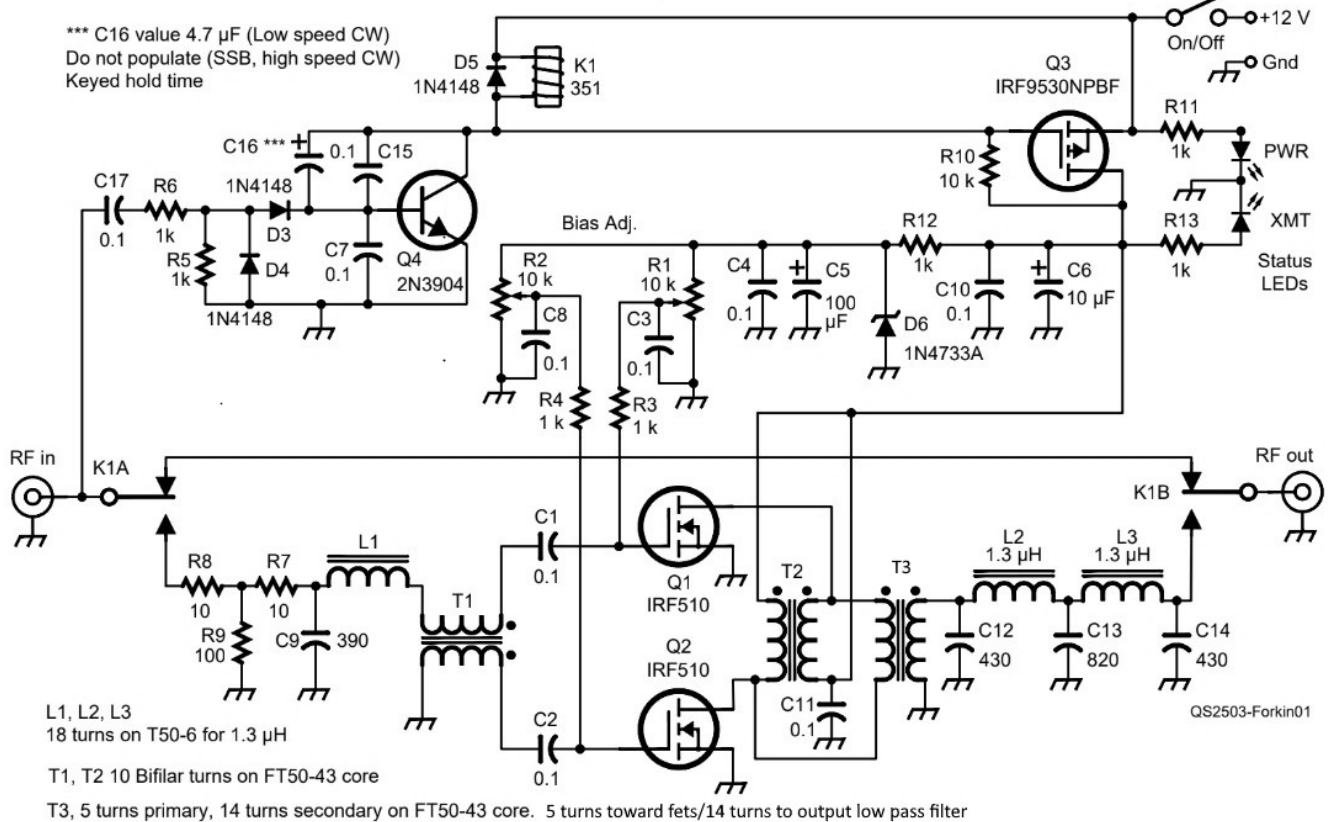

FIGURE 11 Place the assembled circuit board over the six pins of the FETs as shown. Mount the circuit board on standoffs using number 4 hardware and once mounted solidly, solder the six pins from the FETs to the circuit board after the circuit board has been mounted.. Tighten the FET mounting hardware and assure no contact from the center pin of each FET to the enclosure or heatsink. Wire up the power switch, RF input and output jacks and assembly is complete. Proceed to the Adjustments section.



SCHMATIC AS PUBLISHED IN QST MAGAZINE



*** C16 value 4.7 μ F (Low speed CW)
Do not populate (SSB, high speed CW)
Keyed hold time

L1, L2, L3
18 turns on T50-6 for 1.3 μ H
T1, T2 10 Bifilar turns on FT50-43 core

T3, 5 turns primary, 14 turns secondary on FT50-43 core. 5 turns toward fets/14 turns to output low pass filter

VALUES SHOWN HERE ARE FOR THE 60/40 METER VERSION. Note: C9, 120 pF and L1, 15 turns on T50-6 toroid core.

ADJUSTMENT PROCEDURE:

It is necessary to adjust the bias levels on each final for proper gain and linearity. The following steps detail this procedure.

Each bias potentiometer is adjusted so that the current pulled by each final is equal. Do each step below in order

1. Assure each BIAS potentiometer is adjusted fully counter-clockwise.
2. Attach a temporary short from the anode end of D5 (next to the relay) to power ground. That is the end opposite the marked stripe.
3. Connect a 50 ohm load to the RF power output. No connection to the RF input.
4. Set up a multimeter to read DC current and connect in series to the power supply and +12V on the board.
5. Attach the negative power supply connection to amplifier ground. Both LEDs will be on.
6. Measure the current at this stage and then slowly turn R2 (nearest Q2) clockwise and note a 30mA current reading increase. This shows Q2 is drawing 30 mA with no RF drive.
7. Slowly turn R1 (nearest Q1) clockwise and note a 60mA current reading over the initial reading. This shows Q2 is also drawing 30 mA with no drive. The current drawn by each final FET should be as close to equal as possible.
8. Remove the temporary short on D5 to ground and remove the power connections.

Adjustment is now complete and no further adjustments are necessary. If you notice the transmit LED does not completely go out during standby, solder a 2.7k, ¼ watt resistor across it on the circuit board. Place a small heatsink on Q3 after final assembly as it will run hot during heavy usage.

The amplifier is now ready for use. When DC voltage is applied via an on/off switch, the pwr- LED will illuminate. When RF is applied to the RF input jack, both LEDs will be illuminated and the amplifier will automatically dis-connect it's input from the output jack and connect the final low pass filter to the antenna. If no voltage is applied via the on/off switch, the amplifier will remain un-keyed and the output jack will be connected to the input jack allowing signal reception and transmission without any gain.

Do not transmit into this amplifier without a load or antenna on the output as damage to the finals may occur.

**PARTS LISTING FOR THE
WA3TFS QRP AMPLIFIER****All values shown are for 40
meters**Edited 10/12/2022**R1**

PART NO. ON PCB	DESCRIPTION	DIGIKEY NO.	QTY
K1	RELAY, 12V, DPDT	PB384	1
C1-C4,C7,C8,C10,C11,C15,C17	.1 Ceramic capacitor X7R, 50V	K104K15X7RF53K2	10
C5	100 uF electrolytic capacitor, 16 volt	EL1C101MP26311U	1
C6	10 uF electrolytic capacitor, 50 volt	106CKH050M	1
C16 (check schematic note)	4.7 uF electrolytic capacitor, 50 volt	475CKR050M	1
C9	120 Pf ceramic capacitor 250v C0G	FA28C0G2E121JNU00	1
C12, C14	DEPENDS ON BAND	SEE CHART	2
C13	DEPENDS ON BAND	SEE CHART	1
D1, D2		DO NOT INSTALL	2
D3-D5	Switching diode	1N4148	3
D6	Diode, zener, 5.1 volt, 1 watt	1N4733A-TR	1
Q1, Q2	IRF10 N channel MOSFET	IRF510PBF	2
Q3	IRF9530NPBF, P channel MOSFET	IRF9530PBF	1
R1, R2	Trimmer potentiometer, 10 k, ¼ watt	CT6EP103	2
R3-R6, R11-R13	Resistor, ¼ watt, 1000 ohm 5%	CFR16J1K0	7
R7, R8	Resistor, 3 watt, 10 ohm 5%	A106021CT-ND	2
R10	Resistor, ¼ watt, 10 k ohms, 5%	CFR-25B-52-10K	1
R9	Resistor, 3 watt, 100 ohm 5%	A106005CT-ND	1
Miscellaneous Parts:	Items in RED are not available from Digi-Key		
SEE NOTE BELOW			
U\$2, U\$5, U\$6	T50-6 (yellow) toroid core	E-Bay/Amazon, etc.	3
U\$1, U\$3, U\$4	FT50-43 toroid core	Mouser, 5943000301	3
	#24 enamel copper wire	AS NEEDED	
PRINTED CIRCUIT BOARD	WA3TFS 090922-1	Available at http://wa3tfs.com	1
KITS ARE AVAILABLE	ORDER ON WEB SITE	HTTP://WA3TFS.COM	
NOTE: On Q1 and Q2	Use T0220 TRANSISTOR Mounting Kit	4880SG	2

Feel free to substitute manufacturers

—
NOTE: IN THE QST ARTICLE, U\$2 IS L1, U\$1 IS T1, U\$3 IS T2, U\$4 IS T3, U\$5 IS L2 AND U\$6 IS L3

**COMPONENT
VALUES FOR
VARIOUS HF BANDS
WA3TFS QRP AMPLIFIER**

**COMPONENT
VALUES FOR
VARIOUS HF BANDS
WA3TFS QRP
AMPLIFIER**

160/80//75 METERS

U\$2	22T #24 ON T50-6 CORE
U\$5, U\$6	21T #24 ON T50-6 CORE
C12, C14	820 pF
C13	1500 pF
C9	390pF

60/40 METERS

U\$2	15T #24 ON T50-6 CORE
U\$5, U\$6	18T #24 ON T50-6 CORE
C12, C14	430pF
C13	820pF
C9	120pF

30/20/17 METERS

U\$2	9T #24 ON T50-6 CORE
U\$5, U\$6	11T #24 ON T50-6 CORE
C12, C14	180pF
C13	330pF
C9	120pF

15/12/10 METERS

U\$2	8T #24 ON T50-6 CORE
U\$5, U\$6	9T #24 ON T50-6 CORE
C12, C14	120pF
C13	220pF
C9	74pF

RED INDICATES
CHANGES TO ORIGINAL
DESIGN

SCHMATIC FOR THE WA3TFS 20 WATT QRP LINEAR AMPLIFIER FOR 40 METERS-R1

